

syn1588[®]

Visual Measurement System

syn1588[®] VMS

Data Sheet

Version 1.7 – November 10th 2021

Oregano Systems – Design & Consulting GesmbH

Franzosengraben 8, A-1030 Vienna

P: +43 (676) 84 31 04-300

@: contact@oregano.at

W: <http://oregano.at>

0 Legals

Copyright © 2019 Oregano Systems – Design & Consulting GmbH

ALL RIGHTS RESERVED.

Oregano Systems does not assume any liability arising out of the application or use of any product described or shown herein nor does it convey any license under its patents, copyrights, or any rights of others.

Licenses or any other rights such as, but not limited to, patents, utility models, trademarks or trade names, are neither granted nor conveyed by this document, nor does this document constitute any obligation of the disclosing party to grant or convey such rights to the receiving party.

Oregano Systems reserves the right to make changes, at any time without notice, in order to improve reliability, function or design. Oregano Systems will not assume responsibility for the use of any circuitry described herein.

All trademarks used in this document are the property of their respective owners.

0.1 Contents

Visual Measurement System	1
syn1588® VMS	1
Data Sheet.....	1
0 Legals	2
0.1 Contents.....	3
0.2 List of Figures	3
0.3 List of Tables	4
1 Overview	5
1.1 Functional description	5
2 Features.....	7
3 Dimensions and Weight	8
3.1 syn1588® VMS	8
4 Electrical Interface Specification	9
4.1 ESD.....	9
4.1.1 syn1588® VMS	9
4.2 Power Supply	9
4.2.1 syn1588® VMS	9
4.3 1PPS Inputs.....	9
4.3.1 syn1588® VMS	9
5 Environmental syn1588® VMS	12
5.1 Temperature	12
5.2 Humidity	12
6 Installing the syn1588® VMS	13
6.1 syn1588® VMS – Further information	14
7 Further Information	15

0.2 List of Figures

Figure 1: syn1588® VMS.....	5
-----------------------------	---

Figure 2: syn1588 [®] VMS Example application block diagram	6
Figure 3: syn1588 [®] VMS dimensions	8
Figure 4 syn1588 [®] VMS 1PPS Reference Input / 1 PPS Output	10
Figure 5 syn1588 [®] VMS Measurement Inputs.....	11

0.3 List of Tables

Table 1 syn1588 [®] VMS power supply specification.....	9
Table 2 syn1588 [®] VMS: SMA Input Characteristics	10
Table 3 syn1588 [®] VMS: BNC Input Characteristics	11

1 Overview

1.1 Functional description

The syn1588® VMS – Visual Measurement System is a multi-channel, high resolution, high accuracy 1 PPS data acquisition unit for analyzing the synchronization behavior of multiple clock synchronization devices. The syn1588® VMS is based on a Dell 19" 2HE rack-mount server.



Figure 1: syn1588® VMS

syn1588[®] VMS – Data Sheet

The following diagram shows a typical application of the syn1588[®] VMS.

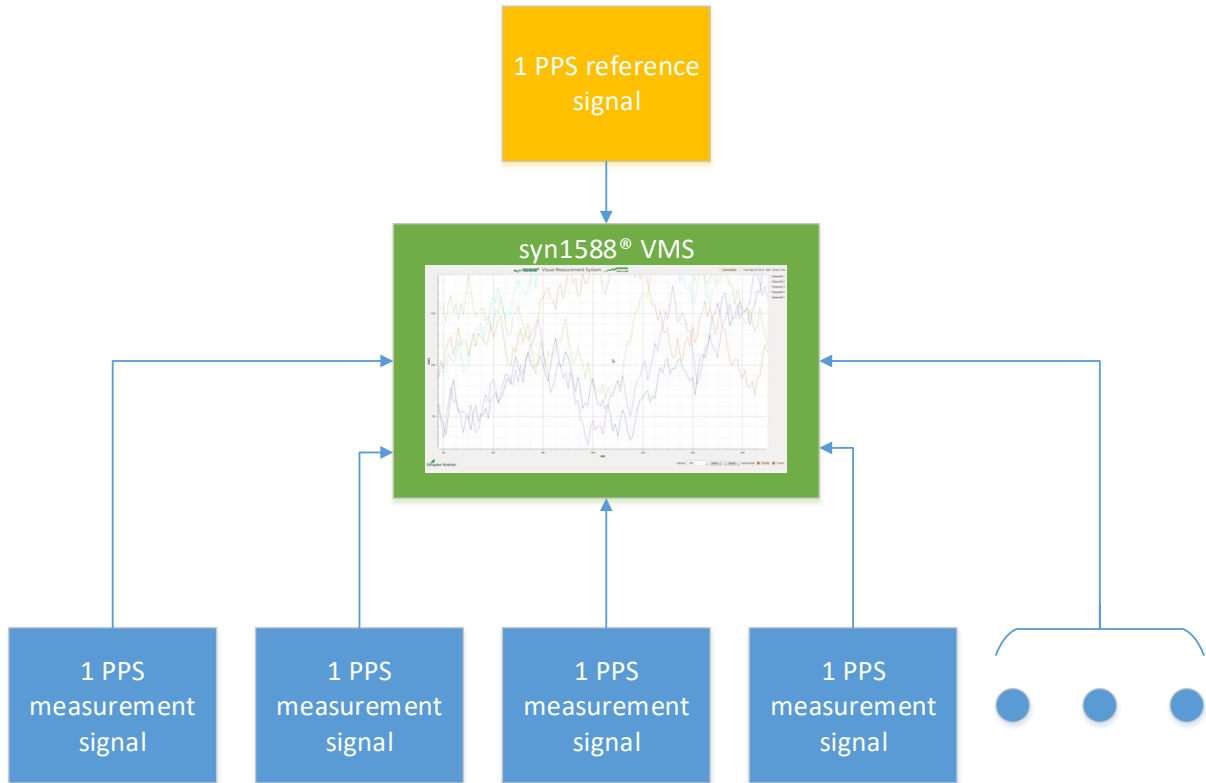

Figure 2: syn1588[®] VMS Example application block diagram

2 Features

The following features are based on the hardware build ID 810 of the syn1588[®] PCIe NIC – Revision 2. Other build versions of the syn1588[®] PCIe NIC will offer somewhat different capabilities. Please contact Oregano Systems' support for details.

- Multi-channel 1 PPS measurement system
- 4 ns resolution
- +/-4 ns accuracy
- 22 measurement channels @ syn1588[®] VMS
- 50 Ω termination and ESD protection for every channel
- LVCMOS levels supported
- Minimum pulse width 50 ns
- Maximum pulse width 500 ms
- User configurable real-time graphic display of 1 PPS signals
- User configurable real-time graphic display of MTIE, TDEV, and ADEV
- Separate data and histogram files generated per channel for external post processing.
- Online statistical data (mean value and standard deviation)
- Online channel status display
- Channel management via configuration file
- Web-based remote display of 1 PPS offset
- Fully automated online checker function
- User-programmable boundaries
- Alerting if channel enters/leaves accuracy boundaries
- High-stability OCXO oscillator

3 Dimensions and Weight

3.1 syn1588® VMS

The following figure shows the dimensions of the syn1588® VMS. The syn1588® VMS is based on a 19" 2HE rackmount server R540 from Dell (<http://www.dell.com>).

System dimensions

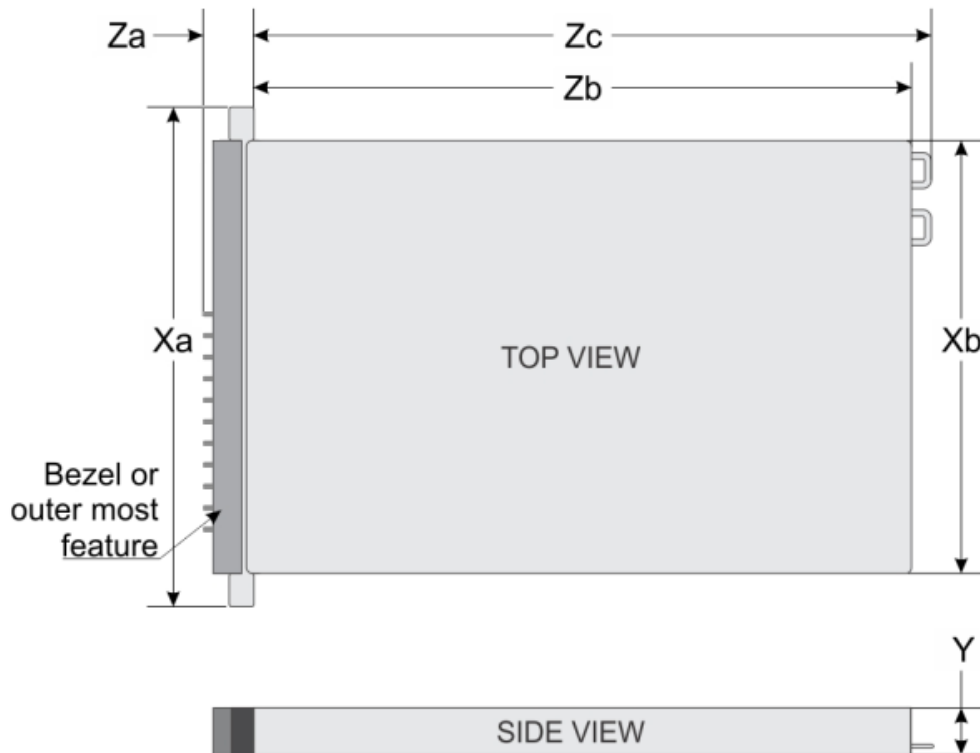

Xa	Xb	Y	Za	Zb	Zc
482.0 mm (18.97 inches)	434.0 mm (17.08 inches)	86.8 mm (3.41 inches)	38.84 mm (1.53 inches)	647.07 mm (25.47 inches)	681.755 mm (26.84 inches)

Chassis weight

Maximum weight

29.68 kg (65.43 lb)

Figure 3: syn1588® VMS dimensions

4 Electrical Interface Specification

4.1 ESD

4.1.1 syn1588® VMS

All SMA connectors of the syn1588® PCIe NIC (rear-side of the syn1588® VMS) are protected against ESD damage following IEC61000-4-2 15 kV air 8 kV contact.

All BNC connectors of the syn1588® VMS (front side) are protected against ESD damage following IEC61000-4-2 15 kV air 8 kV contact.

4.2 Power Supply

4.2.1 syn1588® VMS

The syn1588® VMS is operated from mains. It owns a wide range power supply with the following specifications:

Mains voltage	110 – 240 V
Mains frequency	50 – 60 Hz
Max. power	495W

Table 1 syn1588® VMS power supply specification

4.3 1PPS Inputs

4.3.1 syn1588® VMS

There are 22 BNC connectors (measurement signals) on the front panel and one SMA connector (reference signal) on the rear side of the syn1588® VMS available for the user. The input signals expect a standard 3V3 level signal.

4.3.1.1 Reference SMA Input Characteristics

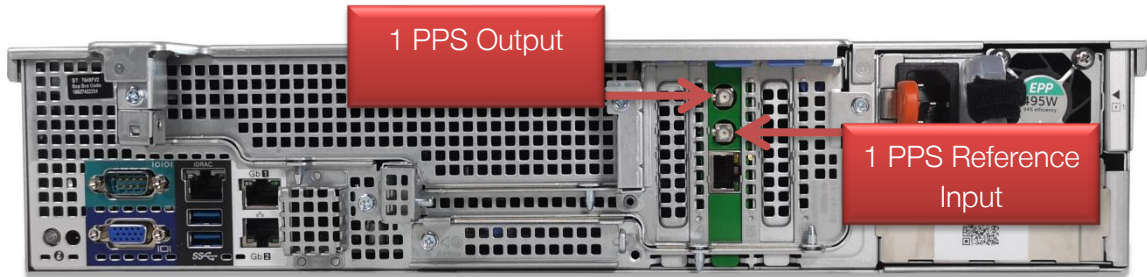

Figure 4 syn1588® VMS 1PPS Reference Input / 1 PPS Output

Input impedance	50 Ω nominal
Input coupling	DC
Voltage level	0 to 3.3 V
Absolute maximum input voltage	-0.5 V to 4.25 V
Minimum pulse width	500 ns
Input threshold high	2.0 V
Input threshold low	0.8 V

Table 2 syn1588® VMS: SMA Input Characteristics

4.3.1.2 BNC Input Characteristics

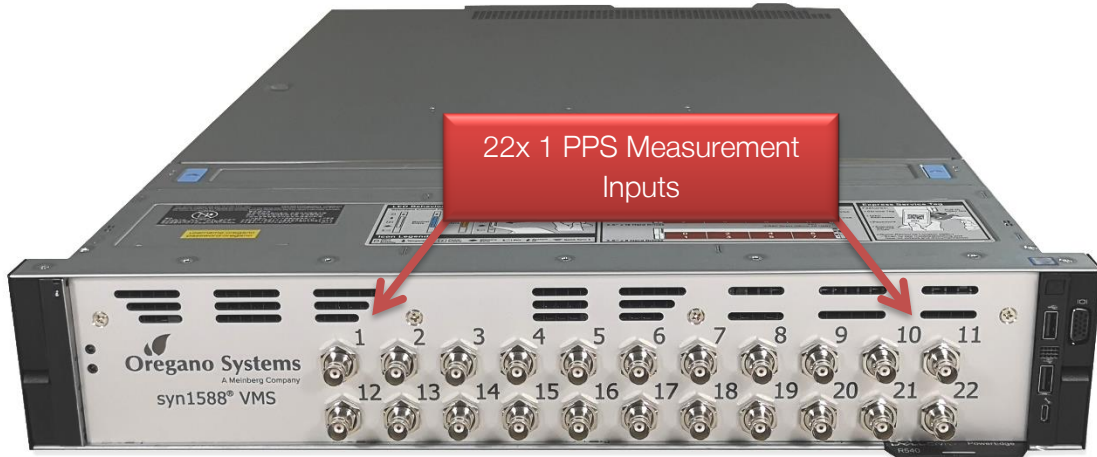

Figure 5 syn1588® VMS Measurement Inputs

Input impedance	50 Ω nominal
Input coupling	DC
Voltage level	0 to 3.3 V
Absolute maximum input voltage	-0.5 V to 4.25 V
Minimum pulse width	500 ns
Input threshold high	2.0 V
Input threshold low	0.8 V

Table 3 syn1588® VMS: BNC Input Characteristics

syn1588® VMS – Data Sheet

5 Environmental syn1588® VMS

5.1 Temperature

Operating temperature range 0° C ... +50° C

Storage temperature range -40° C ... +85° C

5.2 Humidity

Operating humidity 5% to 80% RH, non-condensing

6 Installing the syn1588® VMS

The following instructions are general installation guide lines.

Caution



The syn1588® VMS is sensitive to electrostatic discharge that may damage the unit. Please observe ESD protection rules. Do not directly touch any connectors while not being properly grounded.

Quick installation guide:

1. Unpacking the Rack System

Unpack your system and identify each item. Assemble the rails (optional available for the syn1588® VMS) and install the system in the rack following the safety instructions and the rack installation instructions provided with your system.

2. Connecting the Keyboard Mouse and Monitor

Connect the keyboard, mouse, and monitor. The connectors on the back of your system have icons indicating which cable to plug into each connector. Be sure to tighten the screws (if any) on the monitor's cable connector.

3. Connecting the Power Cable(s)

Connect the system's power cable(s) to the system and, if a monitor is used, connect the monitor's power cable to the monitor.

4. Securing the Power Cable

The syn1588® VMS is delivered with Unique Lockable power cables. This special power cable protects the server from accidental disconnection.

Additional security at syn1588® VMS:

Bend the system power cable(s), and attach to the cable strap. Plug the other end of the power cable(s) into a grounded electrical outlet or a separate power source such as an uninterruptible power supply (UPS) or a power distribution unit (PDU).

5. Turning on the System

Press the power button on the system. The power indicator should light.

6.1 syn1588® VMS – Further information

For further information about how to install a Server please refer to the document “Dell EMC PowerEdge R540 Getting Started Guide” and “Rail Installation Guide”. This documents also can be found here: <http://www.dell.com/support/home/at/en/atbsdt1/product-support/product/poweredge-r540/manuals>

7 Further Information

You are looking for further information not included in this datasheet? Please contact Oregano Systems support! We will be pleased to provide you all the required information.



Franzosengraben 8

A-1030 Vienna

AUSTRIA

<http://oregano.at>

contact@oregano.at

Oregano Systems - Design & Consulting GesmbH
Franzosengraben 8, 1030 Vienna, Austria

Phone: +43 (676) 843104 200

Mail: contact@oregano.at

Web: www.oregano.at

Vienna, September 2012

Certificate of Conformance

The Oregano Systems Ethernet network interface card with IEEE1588 capabilities "syn1588® PCIe NIC" (board revision 1.5) meets the intent of .Electromagnetic Compatibility directive 2004/108/EC, Low Voltage directive 2006/95/EC and safety requirements for electrical equipment for measurement, control and laboratory use.

Compliance was demonstrated to the following specifications:

- EN55022:2010
- EN55024:2010
- EN/IEC60950-1:2005 (2nd Edition)+A1:2009

Oregano Systems – Design & Consulting GesmbH

Gerhard R. Cadek
(CEO)

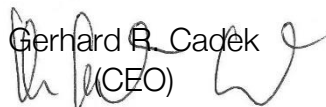

Oregano Systems - Design & Consulting GesmbH
Franzosengraben 8, 1030 Vienna, Austria

Phone: +43 (676) 843104 200

Mail: contact@oregano.at

Web: www.oregano.at

Vienna, September 2012

RoHS Certificate of Conformance

The Oregano Systems' syn1588[®] products listed below is (are) in compliance with Directive 2011/65/EC on the restriction of the use of certain hazardous substances in electrical and electronic equipment (RoHS Directives).

- syn1588[®] Gbit Switch (board revision 1.7)
- syn1588[®] PCIe NIC (board revision 1.5)
- syn1588[®] PCIe NIC Revision 2 (board revision 2.0)
- syn1588[®] VIP Evaluation Board (board revision 2.1)

Oregano Systems – Design & Consulting GesmbH

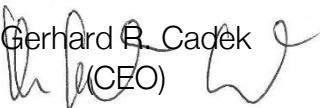
Gerhard R. Cadek

(CEO)

Oregano Systems - Design & Consulting GesmbH
Franzosengraben 8, 1030 Vienna, Austria

Phone: +43 (676) 843104 200
Mail: contact@oregano.at
Web: www.oregano.at

GC | @ cadek@oregano.at | +43 676 84 31 04-200

Wien, November 10th 2015

Letter of Volatility

The following table shows the non-volatile memories of the syn1588[®] PCIe NIC – Revision 2. Please note that no customer data is stored in these non-volatile memories.

memory	function	size	writeable	user R/W	access restriction
SPI Flash U17 Micron N25Q128A13ESF40G	FPGA configuration storage	128Mbit	yes	no	dedicated firmware update software required, only user configuration may be written, factory default configuration is write protected in hardware
I2C EEPROM U1 Microchip 24AA02E48T-I/OT	MAC address	2kbit	no	no	no write access implemented in hardware

(Dr. Gerhard R. Cadek)
CEO