

VoIP Intercom

VoIP Intercom II PoE

Data Sheet

Version 1.21 – November 10th 2021

Oregano Systems – Design & Consulting GesmbH

A Meinberg Company

Franzosengraben 8, A-1030 Vienna

P: +43 (676) 84 31 04-300

@: contact@oregano.at

W: <http://oregano.at>

0. Legals

Copyright © 2021 Oregano Systems – Design & Consulting GesmbH

ALL RIGHTS RESERVED.

Oregano Systems does not assume any liability arising out of the application or use of any product described or shown herein nor does it convey any license under its patents, copyrights, or any rights of others.

Licenses or any other rights such as, but not limited to, patents, utility models, trademarks or tradenames, are neither granted nor conveyed by this document, nor does this document constitute any obligation of the disclosing party to grant or convey such rights to the receiving party.

Oregano Systems reserves the right to make changes, at any time without notice, in order to improve reliability, function or design. Oregano Systems will not assume responsibility for the use of any circuitry described herein.

All trademarks used in this document are the property of their respective owners.

0.1 Versions

Version 1.20, April 2021

- Updated information

Version 1.19, May 2020

- Updated pictures

Version 1.18, March 2019

- New logos and color

Version 1.17, October 2016

- Corrected optocoupler output current

Version 1.16, January 2015

- Added web interface

Version 1.15, June 2014

- New document style and new logos

Version 1.14, January 2014

- Added spec of required plug for external power supply

Version 1.12, July 2011

- Added spec of cable length.

Version 1.11, July 2011

VoIP Intercom II PoE - Data Sheet

- New product pictures, new styling. Small changes with new hardware revision 2.2 (display interface, fuse).

Version 1.10, February 2011

- Added of opto-coupled IO spec tables. Added spec of operating temperature range.

Version 1.9, August 23th 2010

- Update specification of opto-coupled IOs. Added figures for the call button interface.

Version 1.8, March 18th 2010

- Update of handset and microphone description

Version 1.7, February 8th 2010

- Update of the images

Version 1.6, October 8th 2009

- Update of the opto-IOs

Version 1.5, September 25th 2009

- Added images of the new hardware VoIP Intercom II PoE

Version 1.4, August 18th 2009

- Added data to new hardware VoIP Intercom II PoE

Version 1.3, December 18th 2008

- Added SIP protocol support.

Version 1.0, October 30th 2006

- Initial release.

0.2 Contents

VoIP Intercom II PoE	1
Data Sheet	1
0. Legals	2
0.1 Versions	2
0.2 Contents	4
0.3 List of Figures	4
0.4 List of Tables	4
1. Introduction	6
2. System Features.....	7
2.1 New or Changed Function	8
3. VoIP Intercom II PoE Board.....	9
3.1 Features	11
3.2 Interfaces	12
3.2.1 External Power Supply	12
3.2.2 PoE Power Supply.....	12
3.2.3 Ethernet 1 & 2	13
3.2.4 Microphone	13
3.2.5 Speaker.....	13
3.2.6 Handset	14
3.2.7 LED.....	15
3.2.8 Button	15
3.2.9 Serial.....	16
3.2.10 Opto-Coupled IO.....	16
3.2.11 I2C Display Interface	18
3.2.12 Web Interface	18
3.3 ESD.....	18
3.4 Temperature Range	19
4. Mechanical Dimensions.....	19
4.1 Weight.....	19

0.3 List of Figures

Figure 1. VoIP Intercom II PoE Board (Version 2.3.1) – Top View	9
Figure 2. VoIP Intercom II PoE Board (Version 2.3.1) – Bottom View.....	10
Figure 3. Simple, direct connection of up to eight call buttons	15
Figure 4. External keypad matrix enabling up to 36 call buttons.....	16
Figure 5. Opto-coupled outputs: circuit diagram	16
Figure 6. Opto-coupled inputs: circuit diagram	17
Figure 7. Web interface: audio configuration	18
Figure 8. VoIP Intercom II PoE Board V2.2 – mechanical dimensions.....	19

0.4 List of Tables

Table 1 Power supply DC characteristics.....	12
Table 2 Specification of the microphone interface	13
Table 3 Specification of the speaker interface	14

Table 4 Specification of the handset interface	14
Table 5 Specification of the opto-coupled output interface	16
Table 6 Specification of the opto-coupled input interface	17

1. Introduction

Oregon Systems' **VoIP Intercom II PoE Board** enables low-cost voice communication in an industrial environment using an Ethernet network via standard IP protocols. It offers a simple master-slave voice communication between several distributed remote sites and a single central office.



The VoIP Intercom II PoE Board is intended for voice communications like intercoms or emergency telephones etc. in an industrial environment. Unless a conventional IP-telephone the VoIP Intercom II PoE Board offers a rugged, easy-to-use user interface. The system also enables field maintenance and field upgrade capabilities.

2. System Features

Oregon Systems' VoIP Intercom II PoE Board is intended for OEM manufacturers. It does not include any housing, power supply or user interface. The VoIP Intercom II PoE Board offers the following features:

- IP based voice communication
- Both major VoIP protocols are supported
 - H.323 protocol (default shipping option)
 - SIP protocol
 - Optionally both VoIP protocols may be supported in parallel
- Board to board voice communication
- Voice communication from board to a PC running the VoIP Intercom Software and vice versa
- Voice communication from board to any other VoIP software (as simple as Microsoft's NetMeeting) or any standard IP phone
- Voice communication may either be point-to-point or conferencing (3 parties, non-standard firmware)
- Receipt of broadcast calls optionally available (just for SIP protocol)
- Standard 4 kHz voice bandwidth
- Easy-to-use user interface: button-speaker-microphone
- Call is established by pressing a single button
- VoIP Intercom II PoE Boards may run either pre-programmed application or boot their application from a central server
- Static pre-programmed IP configuration or BOOTP/DHCP based auto configuration
- VoIP Intercom II PoE Board enables connecting another local device to the LAN via an integrated on-board Ethernet hub
- More interface options available upon request
- Opto-coupled IOs enable remote controlled actions
- High performance power amplifier for the loudspeaker eases communication under noisy conditions
- Standard external power supply or Power over Ethernet (PoE) following IEEE802.3 (class 0 device)
- Web interface for easy reconfiguration

2.1 New or Changed Function

The following list lists the new or changed functions of the VoIP Intercom II PoE Board compared to its predecessor the VoIP Intercom II Board.

- Power over Ethernet (PoE) supply following IEEE802.3
- Handset interface controlled by a hook switch input
- 3V3 supply (200 mA) available on LED connector
- Twice the capacity of the on-board Flash memory
- Twice the capacity of the on-board DRAM memory
- Optimized connector placement
- I2C display connector

Please note that neither the boards dimension nor the position of the mounting hole changed!

3. VoIP Intercom II PoE Board

The VoIP Intercom II PoE Board serves as the user interface in a VoIP system. The VoIP Intercom II PoE Board may either run a pre-programmed application (the VoIP Intercom II PoE Firmware) from the on-board Flash memory or boot the application from a central server. In the latter case standard boot protocols like TFTP, BOOTP, and DHCP are supported. Booting the board from a central server enables in-system upgrades.

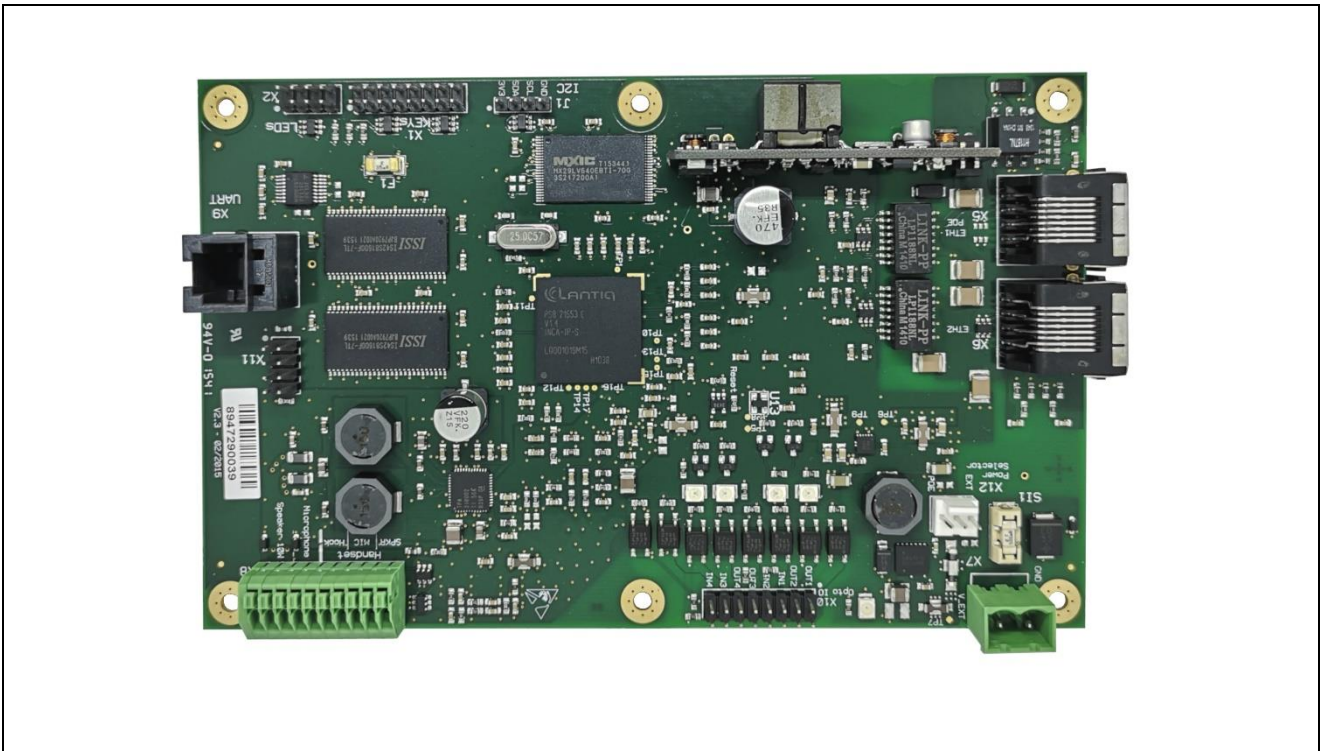

Figure 1. VoIP Intercom II PoE Board (Version 2.3.1) – Top View

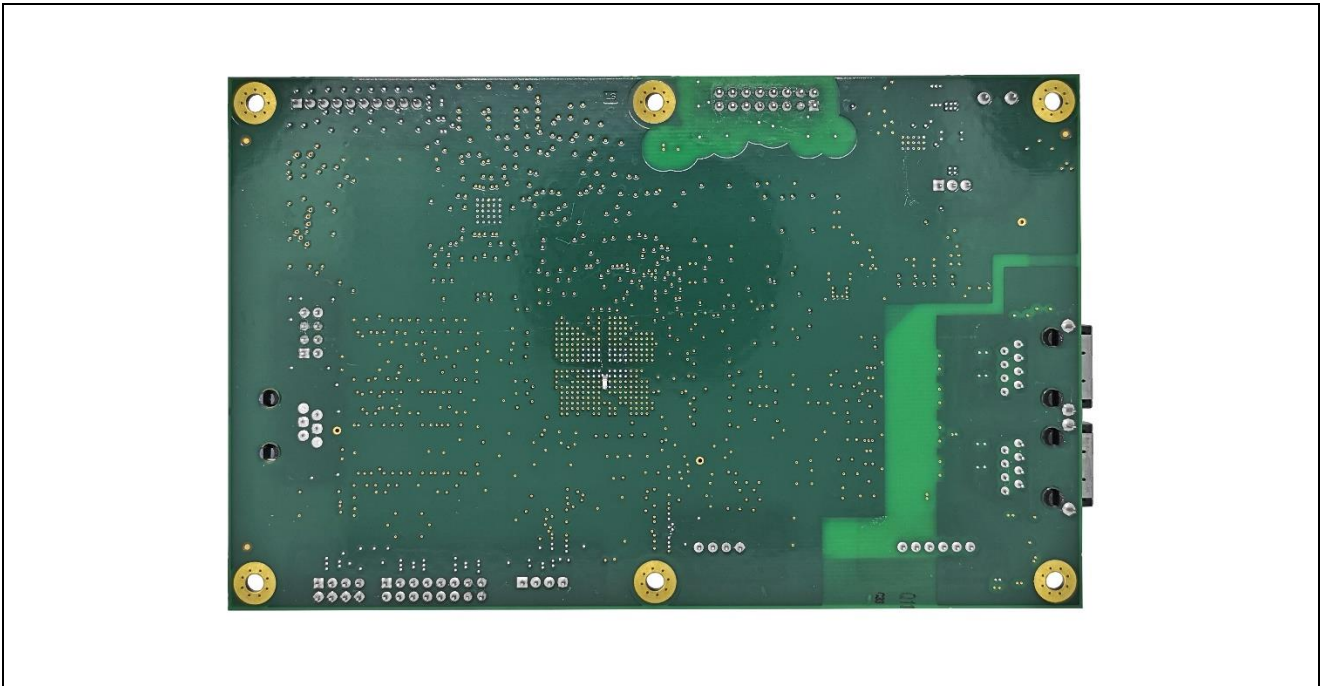

Figure 2. VoIP Intercom II PoE Board (Version 2.3.1) – Bottom View

The VoIP Intercom II PoE Board includes a two-port Ethernet switch enabling the connection of another IP device without requiring any additional cabling or external hub or switch device. The VoIP Intercom II PoE Board will act as a standard internet device having a unique MAC-address and the capability to communicate with a DHCP server to obtain an Internet address within the target system. The VoIP Intercom II PoE Board runs a firmware based on the Linux operating system.

3.1 Features

- Request and receive VoIP calls using either H.323 protocol or SIP protocol
- Standard audio codecs: G.711 (A-law, μ -law), G.726 (16/24/32/40 kbit/s)
- Enhanced audio codecs: G.723.1 (5.3/6.3 kbit/s), G.729
- Optional audio codec: G.722
- Call request issued by pressing a single button to a fixed programmable address
- Incoming calls are answered automatically (if there is currently no active call)
- Up to eight pre-programmable call buttons available
- Up to 36 pre-programmable call buttons available when using external encoded keyboard
- Up to three LEDs available
- VoIP Intercom II PoE firmware located in the on-board Flash - standalone operation- or booted from a server using standard protocols like TFTP, FTP, BOOTP, DHCP - remote controlled operation
- Static IP configuration or dynamic configuration using DHCP
- Second Ethernet interface available for connecting another IP device to the network via the on-board Ethernet hub (repeater)
- External user interface enables simple customization (CI design)
- microphone and speaker for hands-free operation
- handset operation supported controlled by hook input
- 10 W on-board audio amplifier
- serial interface (maintenance interface)
- 4 opto-coupled outputs and inputs
- I2C display interface for simple 2-row character displays (special 3V3 display types qualified by Oregano Systems)
- Single unregulated DC supply (12 to 24 V DC) or PoE following IEEE802.3
- Simple web interface for maintenance

3.2 Interfaces

3.2.1 External Power Supply

The VoIP Intercom II Board is operated with an unregulated DC power supply. Please note that the VoIP Intercom II PoE board's DC supply is protected with a fuse 0,5 A (default factory setting). When requiring maximum output power, one needs to adapt this fuse to allow higher currents. Please contact Oregano Systems' support for receiving the specification of the fuses. Oregano Systems delivers upon request the VoIP Intercom II PoE boards also with different fuse ratings.

Standard fuse type (allows approx. 5 W speaker output power @12 V or 10 W @24 V):

- Littlefuse 0453.500.MRL (500 mA / slow blow)

Caution

Using inappropriate fuses or wrong fuse ratings may cause severe damages of the board and its environment! In case of doubt please contact Oregano Systems' support.

DC Characteristics	
Minimum DC input voltage	12 V
Maximum DC input voltage	24 V
Maximum DC supply current @ 12 V	0,5 A
Maximum DC supply current @ 12 V with audio amplifier 10 W @ 8 Ohm	1,5 A

Table 1 Power supply DC characteristics

Connector:

- Phoenix Contact Part No 1755736

Required Plug:

- Phoenix Contact Part No. 1792249 or

(There are a lot of compatible products to the connector Phoenix Contact Part No 1755736. For detailed information please take a look at the Phoenix Contact website www.phoenixcontact.com)

3.2.2 PoE Power Supply

The VoIP Intercom II PoE Board may be operated with via Power over Ethernet, briefly referred to as PoE. For this the Ethernet connector 1 (X5) must be used. In PoE mode the total power consumption of the board is limited to approx. 13 W.

Selection of PoE mode or external power supply mode is done either using the Jumper X12 or fixed by 0 E resistors (inserted R4 defines PoE mode, inserted R46 defines external power supply mode).

3.2.3 Ethernet 1 & 2

There are up to two 10/100 Mbit/s Ethernet interfaces available on the VoIP Intercom II Board. Ethernet interface 1 (X5) is used for connecting the VoIP Intercom II Board to the network as well as for supplying the power in PoE mode.

A second Ethernet interface is optionally available (connector X6). It is connected via an integrated 3-port switch with the network thus enabling the connection of another network device without external components.

3.2.4 Microphone

A standard Electret microphone suited for an operating voltage of 1.5V is connected to the VoIP Intercom II PoE Board via this interface. The microphone input is specified as follows. The maximum cable length for connecting the microphone shall not exceed 1 m.

Parameter	Conditions	Value
Input Impedance	with AC-coupled 40 mVp-p	12 k Ω – 20 k Ω
Input Voltage Swing	36dB, $V_{DD} = 3.3V$	19 mVp
Input Voltage Swing	differential 0dB	1,2 Vp

Table 2 Specification of the microphone interface

Connector:

- Phoenix Contact PTSA 0,5/10-2,5-F (X8)

3.2.5 Speaker

The VoIP Intercom II PoE Board offers speaker interface for standard 4-8 Ohm speakers. The maximum cable length for connecting the speaker shall not exceed 1 m. Please contact Oregon Systems' support in case you require larger cable lengths. We recommend attaching feed-through ferrites (e.g. Würth type 7427013 or 7427141) onto the speaker cables when length is greater than 0,5 m and noisy or sensitive environment.

Caution

One shall use cables with appropriate dimensions for your selected output power! Drawing 10 W @ 4 Ω equals to 2,5 A! Please contact Oregon Systems' support in case of doubt.

Please note that the VoIP Intercom II PoE board's DC supply is protected with a fuse 0,5 A (default factory setting). When requiring maximum output power, one needs to adapt this fuse to allow higher currents. Please contact Oregano Systems' support for receiving the specification of the fuses. Oregano Systems delivers upon request the VoIP Intercom II PoE boards also with different fuse ratings.

Caution

Using inappropriate fuses or wrong fuse ratings may cause severe damages of the board and its environment! In case of doubt please contact Oregano Systems' support.

Parameter	Speaker	Output Power
Load impedance	4 Ω	15 W @ 24 V
Load impedance	8 Ω	10 W @ 24 V
Minimum load impedance	4 Ω	

Table 3 Specification of the speaker interface

Connector

- Phoenix Contact PTSA 0,5/10-2,5-F (X8)

3.2.6 Handset

The VoIP Intercom II PoE Board offers a handset interface that is activated by the hook input. Please note that handset operation is available alternatively to the hands free operation (microphone/speaker) but not in parallel.

A standard Electret microphone suited for an operating voltage of 1.5V is connected to the VoIP Intercom II Board via this interface. The handset interface is specified as follows.

Parameter	Conditions	Value
Input Impedance Handset Mic	with AC-coupled 40 mVp-p	12 kΩ — 20 kΩ
Input Voltage Swing Handset Mic	36dB, V _{DD} = 3.3V	19 mV _p
Input Voltage Swing Handset Mic	differential 0dB	1,2 V _p
Output Voltage Swing Handset Speaker	Load = 200 Ω	1,6 V _p

Table 4 Specification of the handset interface

Connector

- Phoenix Contact PTSA 0,5/10-2,5-F (X8)

3.2.7 LED

The LED interface is made up of a standard two row header. The LED connector is a two row 8-pin header and offers connection for 3 LEDs. Beside the pure LED signals there is also a 3V3 power supply that may be used for e.g. for illumination of a display etc.

This 3V3 power supply may be loaded with a maximum current of 200 mA. Please note that due to safety reasons this power supply connection is protected by a fuse. Standard fuse type:

- Littlefuse 0451.315.MRL (315 mA / fast)

3.2.8 Button

The button interface is made up of a standard two row header. The button connector is a two row 16-pin header and offers connection for up to 36 buttons (scan matrix). The following figure shows the simple connection of up to eight call buttons.

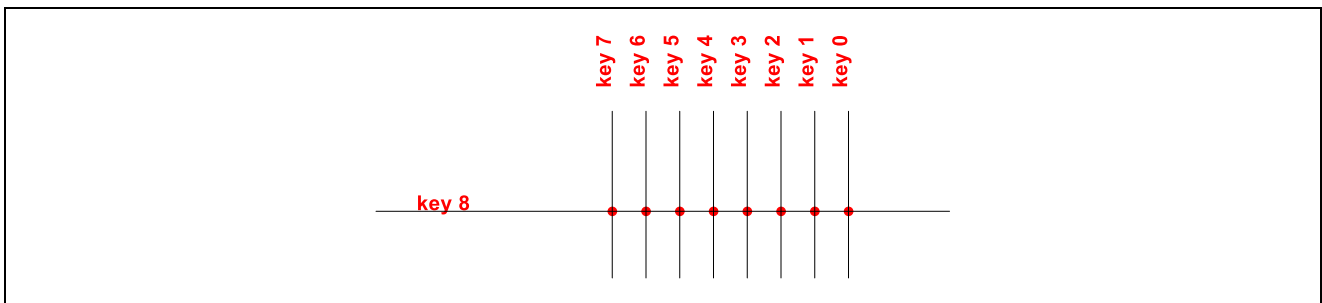

Figure 3. Simple, direct connection of up to eight call buttons

The next figure shows the connection of an external keypad matrix that enables to connect up to 36 call buttons.

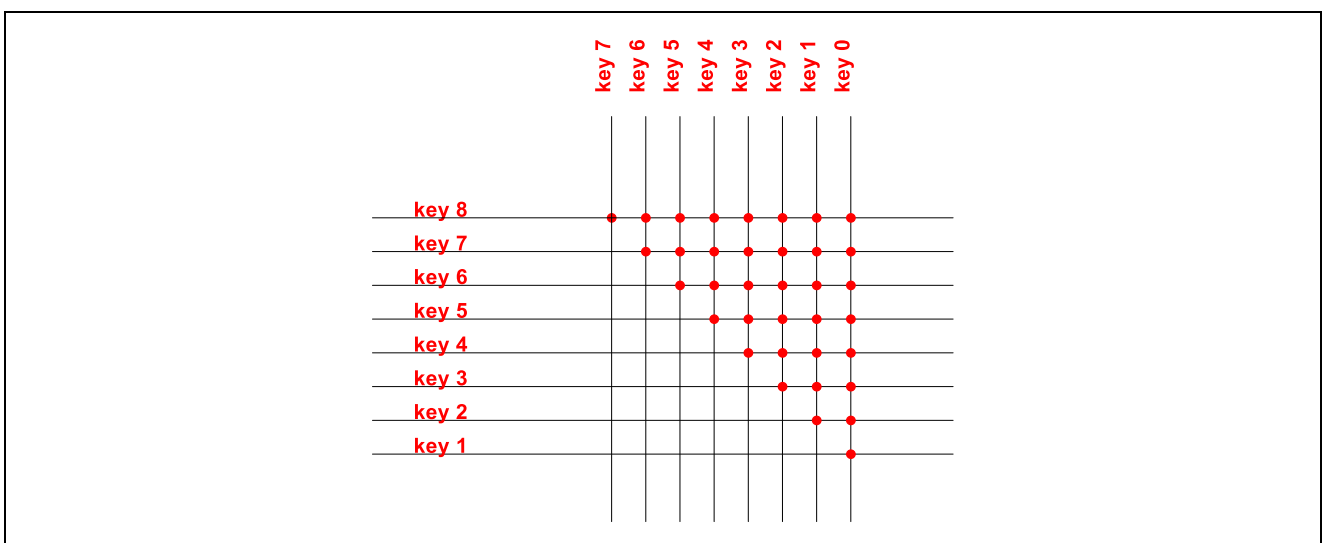

Figure 4. External keypad matrix enabling up to 36 call buttons

3.2.9 Serial

The serial interface is just used for maintenance purpose. The serial interface is available as a RJ11 connector. Parameter settings of the serial interface are: 115200 baud, 8 bit data, 1 stop bit, no parity

Connector

- RJ11

3.2.10 Opto-Coupled IO

There are four opto-coupled inputs and outputs available. The opto-coupled IO connector is a two row 8-pin header. The opto-coupled outputs enable switching of a maximum of 6 mA (25 mA since production date 01/2017) with a maximum voltage of 40 V.

Parameter	Conditions	until production-date 2016	since 2017
Maximum output voltage		40 V	40V
Maximum output current		6 mA	25mA

Table 5 Specification of the opto-coupled output interface

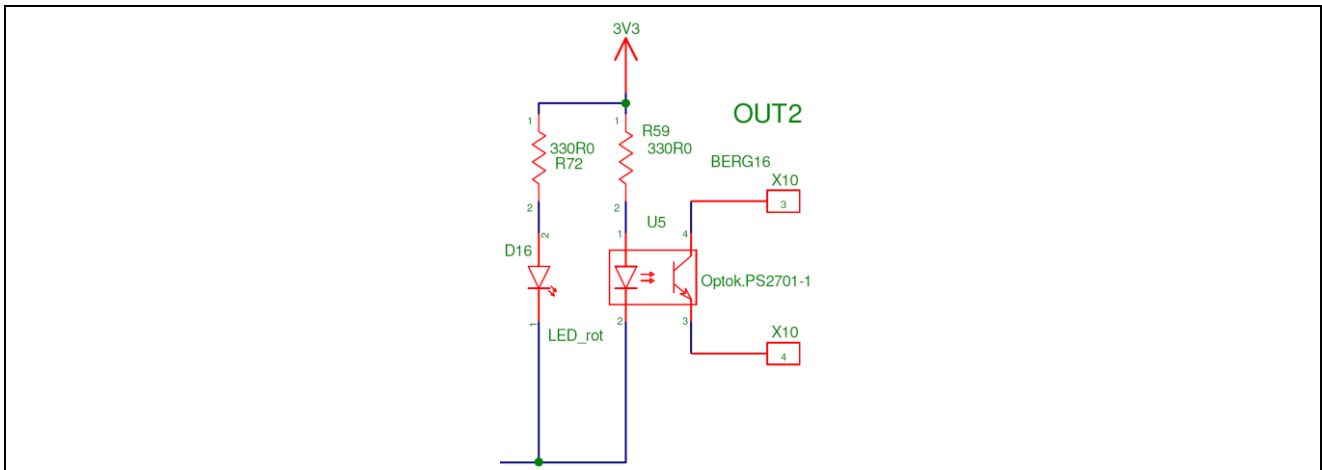

Figure 5. Opto-coupled outputs: circuit diagram

The opto-coupled inputs have to be fed with a current in the range of 5 mA to 40 mA. There is a 330 Ohms series resistor foreseen on the VoIP Intercom II PoE board. When applying higher voltages and thus input currents one has to add an additional external series resistor in order to maintain the current in the specified range.

Parameter	Conditions	Value
Minimum input current		5 mA
Maximum input current		40 mA

Table 6 Specification of the opto-coupled input interface

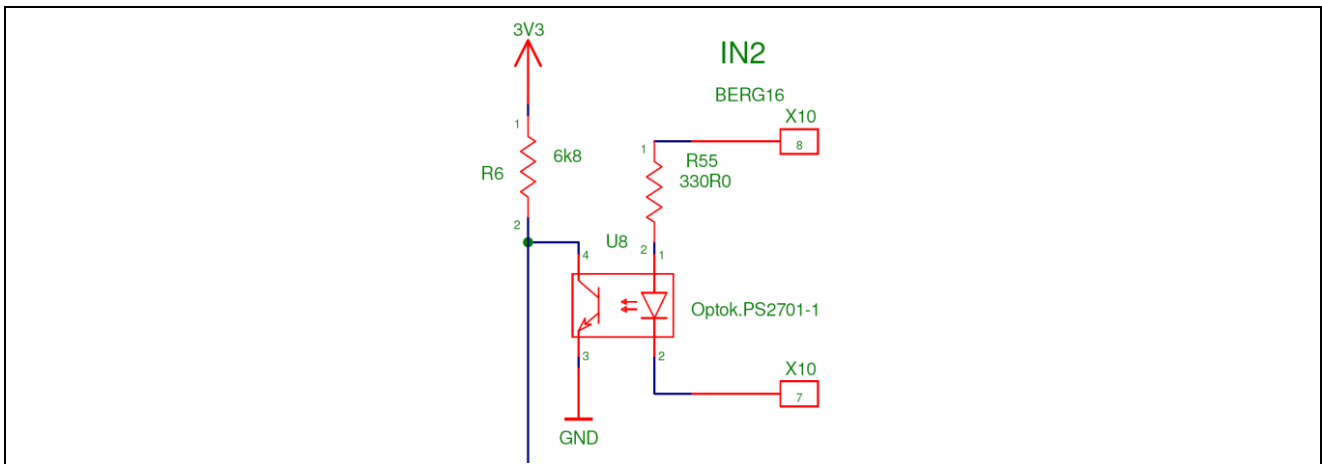

Figure 6. Opto-coupled inputs: circuit diagram

3.2.11 I2C Display Interface

Starting with hardware revision 2.2 there is an I2C display interface on connector J1. The support for connecting simple 2-row character displays (3V3 types) will be added to the VoIP Intercom firmware in the near future. Oregano Systems will qualify a list of displays that may be connected to this interface.

The I2C display interface is made up of a standard single row 4-pin header.

3.2.12 Web Interface

A web interface is included in the VoIP Intercom II firmware. The web interface can be used to reconfigure an already mounted VoIP Intercom II board or to check for the system status. It is intentional kept simple to ensure an easy access to the controls of the VoIP Intercom II board.

With this interface the network configurations may be changed as well as the audio configurations and the VoIP-phone settings. Furthermore the boot options of the VoIP II board may be changed.

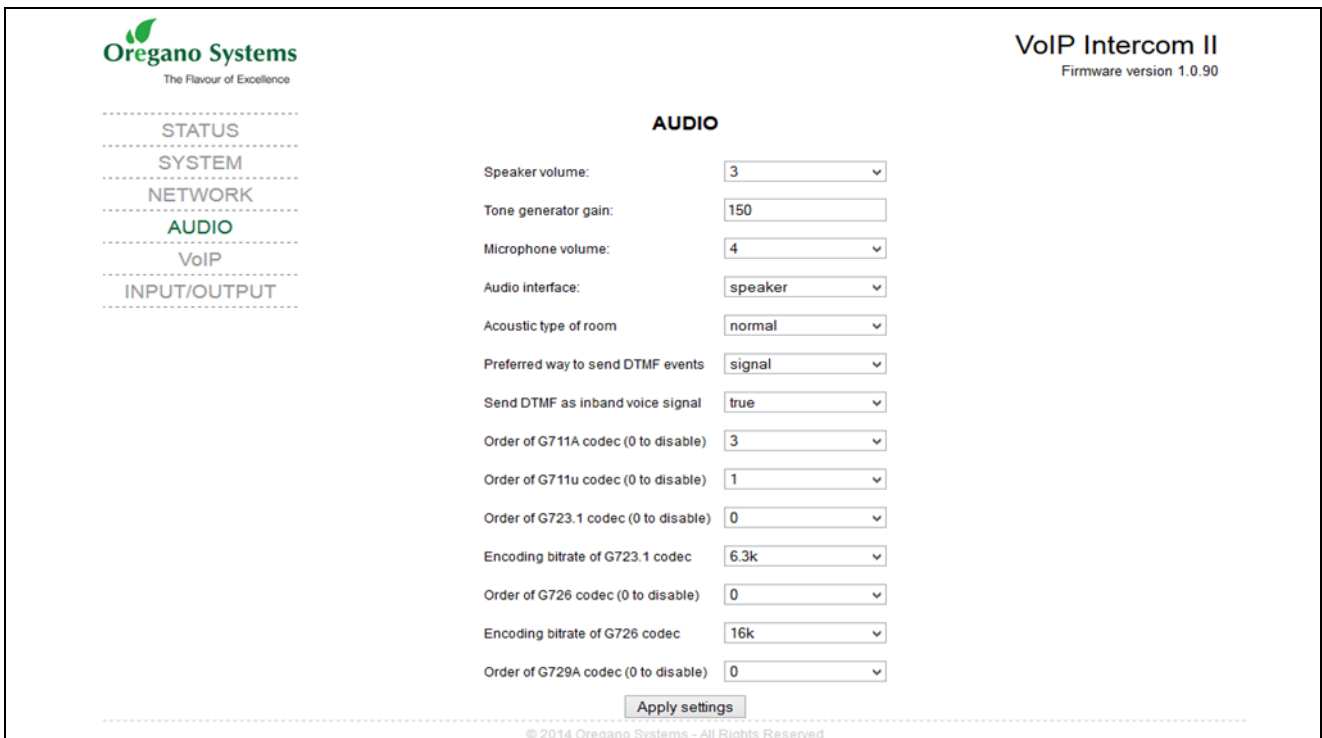

Figure 7. Web interface: audio configuration

3.3 ESD

The VoIP Intercom II PoE Board (except the opto-coupled IO) is protected against ESD damage following IEC61000-4-2 15 kV air 8 kV contact. The opto-coupled IO is protected up to 3,75 kV.

3.4 Temperature Range

The operating temperature range is 0 to +60 degree Celsius. We tested the VoIP Intercom II PoE board successfully in the range of -20 to +60 degree Celsius (non-condensing).

The VoIP Intercom II PoE Board may be ordered coated to prevent from damages in condensing environment.

4. Mechanical Dimensions

All dimensions in mm

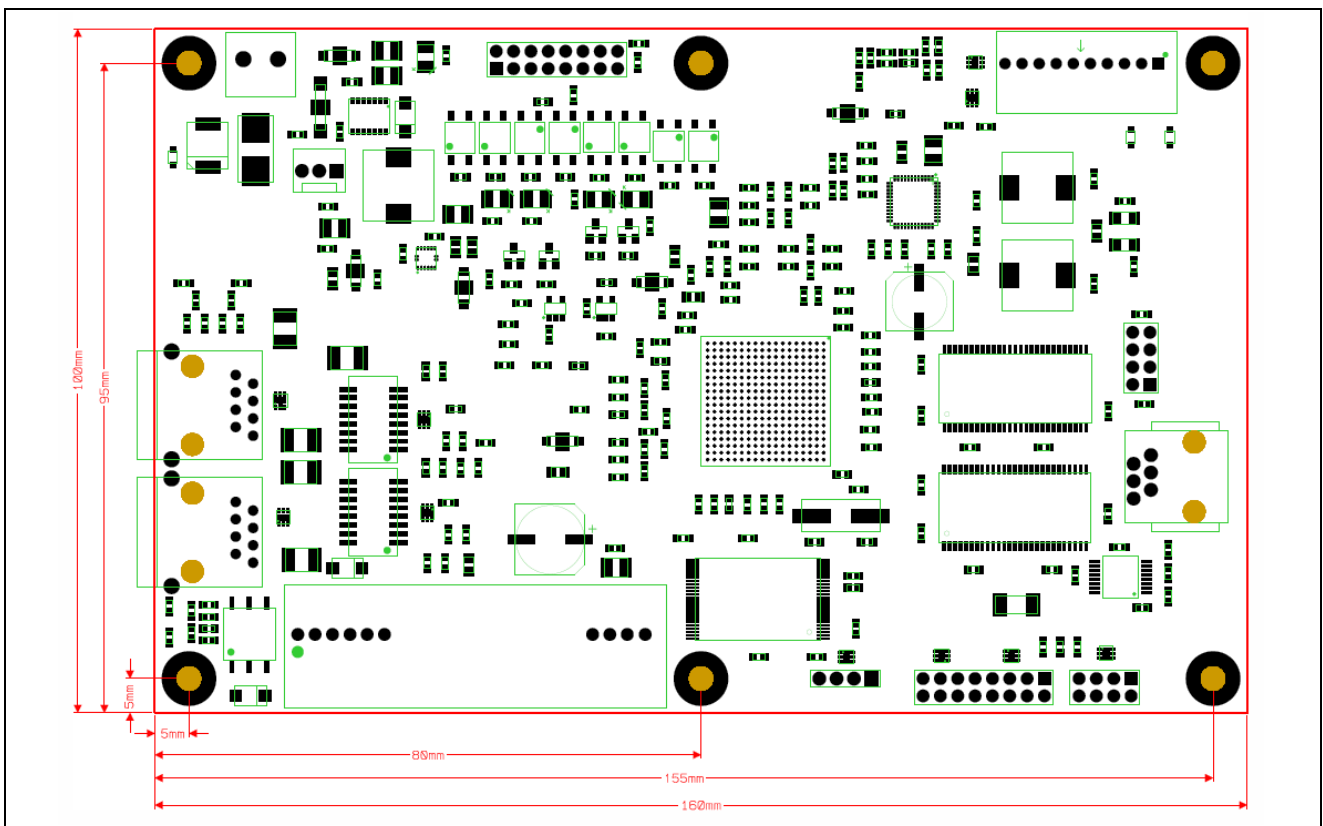

Figure 8. VoIP Intercom II PoE Board V2.2 – mechanical dimensions

4.1 Weight

Total weight of the board approx. 115 g

Oregano Systems - Design & Consulting GesmbH
Franzosengraben 8, 1030 Vienna, Austria

Phone: +43 (676) 843104 200
Mail: contact@oregano.at
Web: www.oregano.at

GC | @ cadek@oregano.at | +43 676 84 31 04-200

Vienna, April 20th 2021

WEEE status of the product

This product is handled as a B2B category product. In order to secure a WEEE compliant waste disposal it has to be returned to the manufacturer. Any transportation expenses for returning this product (at its end of life) have to be incurred by the end user, whereas Oregano Systems will bear the costs for the waste disposal itself.

RL 94/62/EG status of the packaging material

This packaging material is handled as a B2B category packaging material. In order to secure a RL 94/62/EG compliant waste disposal it has to be returned to the manufacturer. Any transportation expenses for returning this product have to be incurred by the end user, whereas Oregano Systems will bear the costs for the waste disposal itself.



Gerhard R. Cadek
(CEO)