

A low-power high-accuracy 10 Gbit PTP Solution

www.oreganosystems.at



The Synchronization Experts.

Oregano Systems
A Meinberg Company

10 Gbit PTP

Gerhard R. Cadek, Oregano Systems

Agenda

- Motivation
 - syn1588[®] 10Gbit NIC - Overview
 - Target applications
 - Details: PCIe, 10G Ethernet MAC, PTP IP core, clocking
 - The Lattice Certus Pro NX advantage
 - Summary
- 

Motivation

- Oregano Systems offers PTP solutions for more than two decades
 - IP Cores
 - Software for Embedded CPUs, Linux and Windows
 - Products
- The syn1588[®] NICs are our main product
 - 100Mbit, 1000Mbit
 - Starting from PC104, PCI, PCIe
- Extend the product portfolio
 - Showcase for our IP cores and software

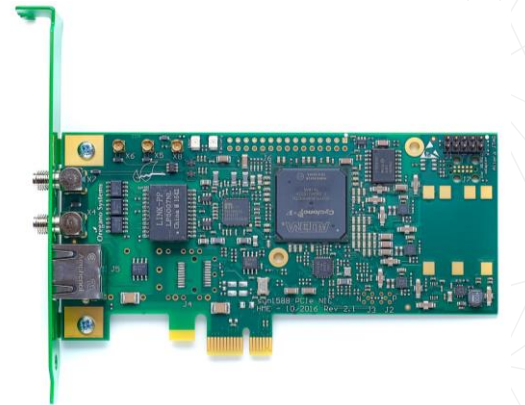

syn1588[®] 10G NIC

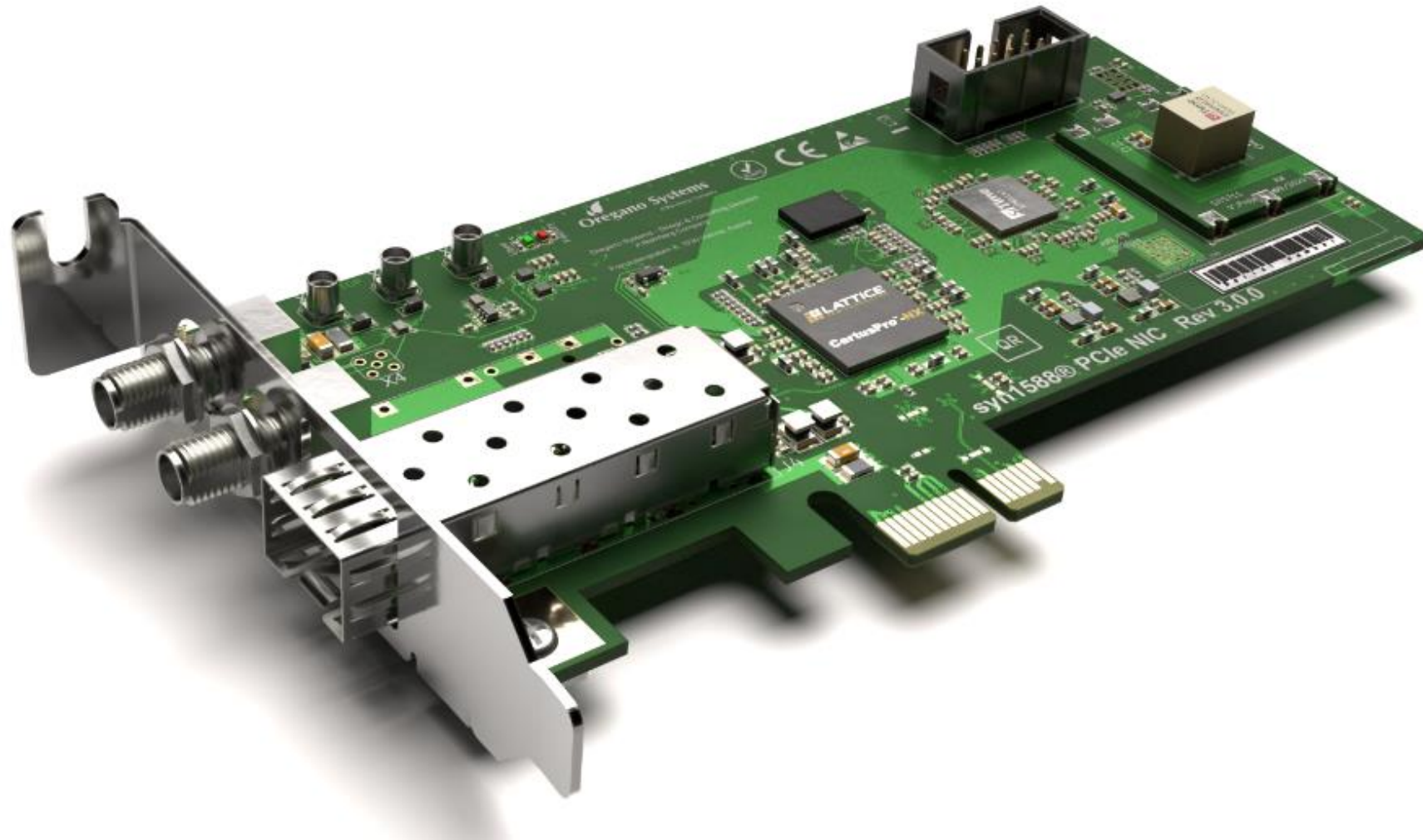

syn1588[®] 10G NIC - Overview

- PCIe x1 card
 - PCIe Revision 3
- Standard 10 Gbit Ethernet NIC
- High-accuracy PTP features included
- Dedicated PTP board infrastructure
 - High performance TCXO oscillator (MEMS device)
 - High-stability OCXO oscillator (MEMS device) as an option
 - External jitter cleaner PLL



syn1588[®] 10G NIC – Overview II

- SFP+ type network interface
- SMA connectors for user I/O
 - 1PPS I/O, generated clocks, IRIG-B,....
 - 50 Ω , 3V3 IOs
- 10 Gbit PTP packet timestamping
- PTP 1-step support
- Accuracy better than 10 ns



Target Applications

- syn1588[®] 10G NIC enables 10 Gbit PTP connectivity
- Intended to add high-accuracy PTP features to
 - PCs and/or Servers
- Enables PTP nodes to attach to high-performance networks
 - Standard 1000 Mbit interfaces are no longer available
 - E.g. in Telecom, Datacenter, and professional Audio & Video environments
- Windows and Linux OS supported



syn1588[®] 10G NIC's Main Focus

Best in Class PTP Timing Performance



syn1588[®] 10G NIC – Block Diagram



syn1588[®] 10G NIC – Main Components

- FPGA
 - Lattice - Certus Pro NX LFCPNX-100-9LFG672I
- PLL
 - TI - LMK5C33414
- Oscillators
 - SiTime - SiT5336 (TCXO) or SiT5711 (OCXO)



syn1588[®] 10G NIC – FPGA Block Diagram

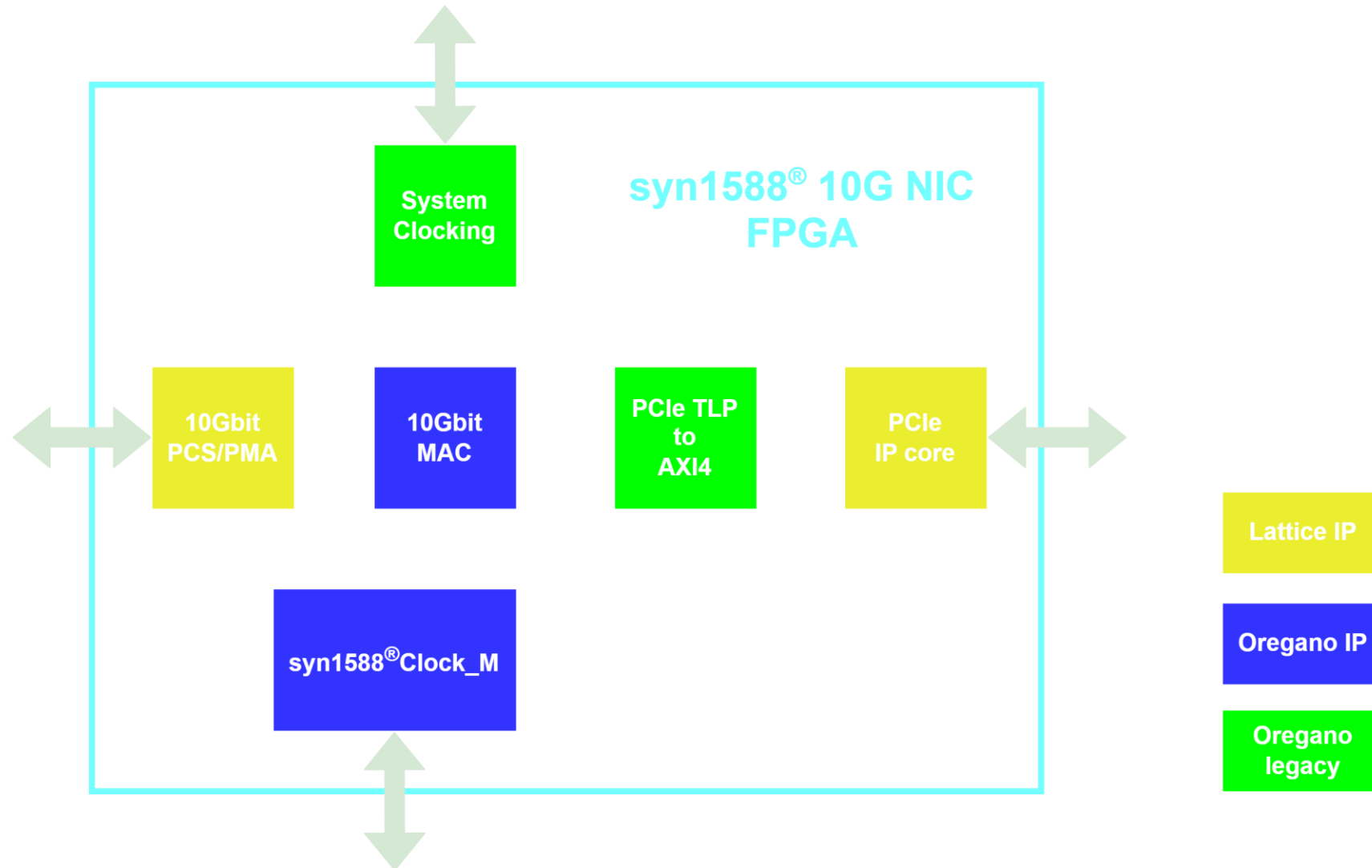

PCIe Features

- PCIe x1 interface – Revision 3
 - optimized for PTP performance
 - not intended for maximum 10 Gbit throughput
 - PCIe x4 interface available upon request
- Lattice PCIe IP core with TLP (Transport Layer Packet) streaming interface
 - Endpoint only with master and slave operation

PCIe Features II

- Custom TLP processing
 - Better control of throughput
 - Better control of arbitration
- RX – decode incoming TLP and convert to AXI transactions
- TX – convert AXI master transactions to TLP messages
- MSI-X interrupt message generation



PCIe Block Diagram

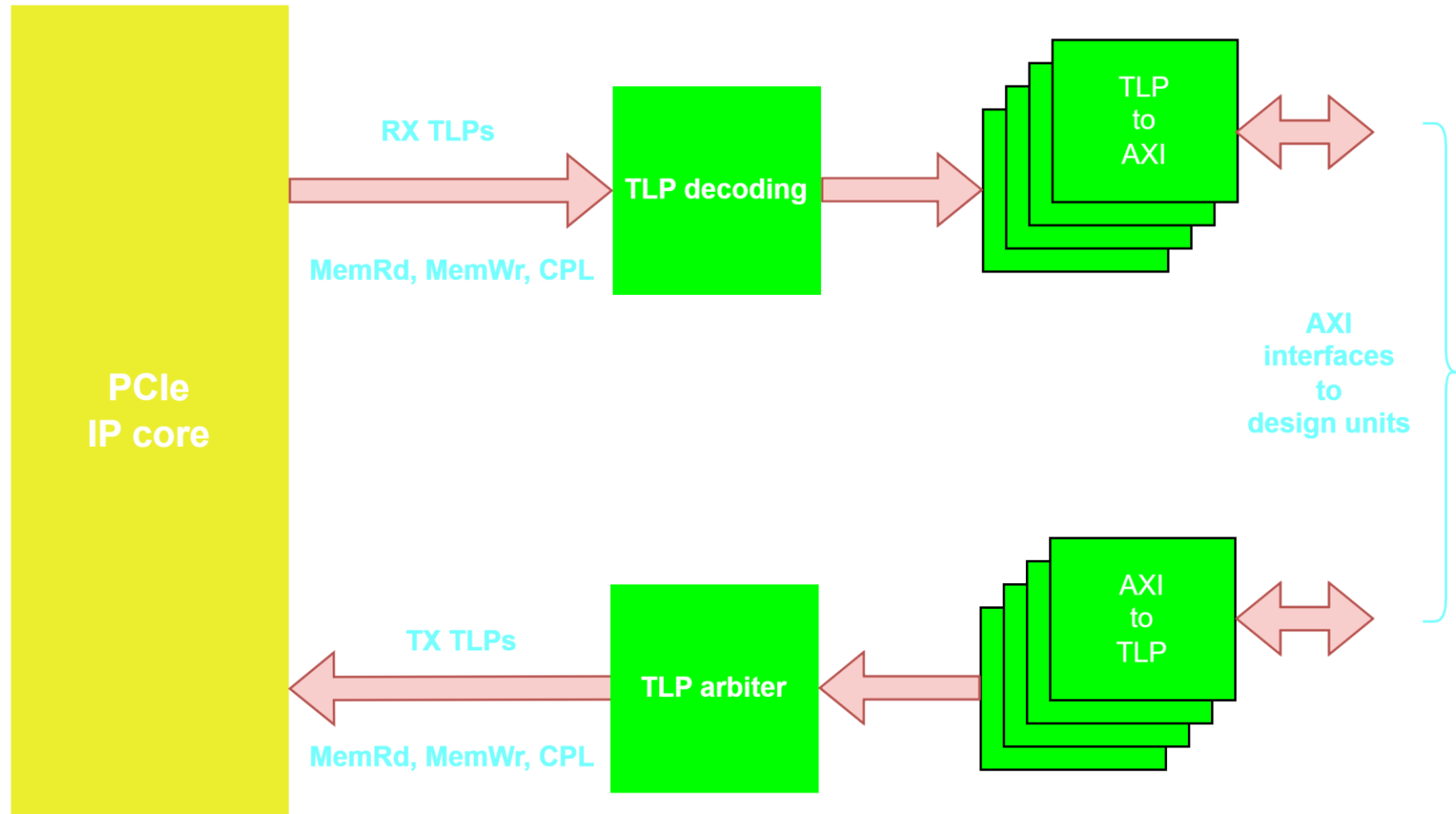

10 Gbit Features

- Oregano Systems' 10G Ethernet MAC
 - With PTP timestamping including 1-step and 2-step support
- Timestamps travel with packets to the software application layer
 - Linux OS (SO_TIMESTAMPING Ifc. + PHC Ifc.)
- AXI bus interface
 - Follower and Leader
- Optional streaming interface
 - Intended for pure hardware processing



10 Gbit Features II

- Full 10Gbit bandwidth
 - Up to the physical limits of the network
 - With PTP timestamping
 - PTP 1-step and 2-step support



Clocking Features

- Most important for a PTP card
- Stable and accurate local reference frequency
 - TCXO or optionally high-stability OCXO oscillator
 - External clock input
- Central on-board PLL
 - Creates all required system clocks and provides Sync-E frequencies
 - Acts as jitter cleaner PLL for user applications
 - Allows implementation of analog control loops with PTP → pushes accuracy to less than 5ns!

Clocking Features II

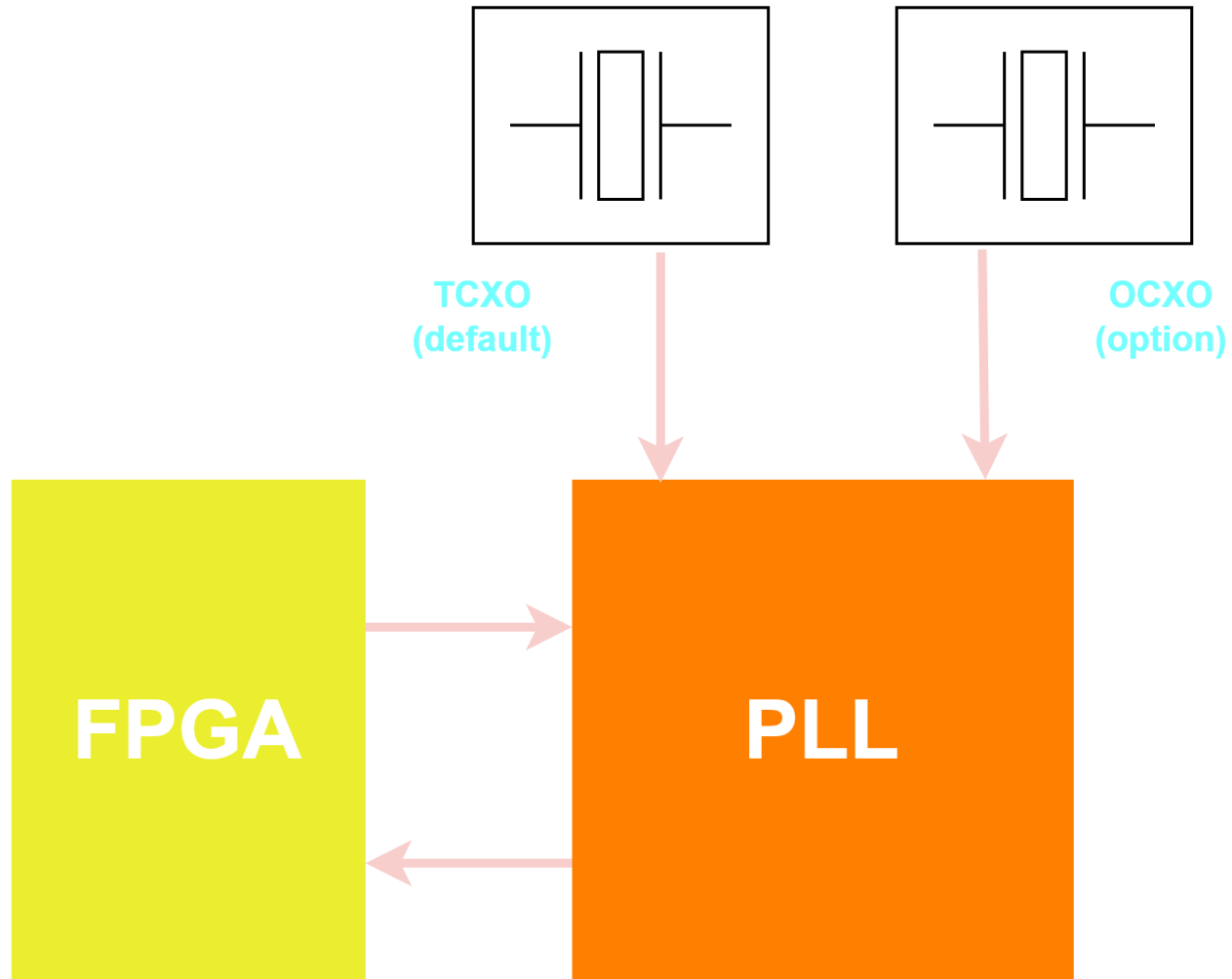

Clocking Features III

- Optionally run syn1588[®] hardware clock driven by external reference frequency
- Generate clock signals from the syn1588[®] hardware clock
 - Accurate period
 - Identical clock signals across all syn1588[®] devices in a network
 - Optionally with defined phase
 - Identical phase of generated clocks across all syn1588[®] devices in a network

FPGA – Some Numbers

- Datapath design 64 bit @ 156.25 MHz
 - Required by 10Gbit interface
- 150 MHz internal PCIe bus frequency (@32 bit)
- Resources
 - Registers 20000 out of 80769
 - LUT4 24000 out of 79872
 - Block RAMs 73 out of 208



PTP Features

- Oregano Systems' well known PTP IP core
 - syn1588[®]Clock_M
- Optional high-stability OCXO oscillator
 - Improved hold-over
- Support for Layer 2, IPv4, IPv6
 - All optional with VLAN
- All timing critical tasks done in hardware



PTP Features II

- Software implements high level tasks
 - syn1588[®] PTP Stack
 - Protocol handling
 - Clock servo algorithm
 - With relaxed software latency requirements
 - Allows usage of non-real-time OS like Linux or Windows
- Support for numerous PTP timing profiles
 - E.g. SMPTE, telecom, power,...



PTP Features III

- Timestamping of external signals
 - Required e.g. when connection a GPS receiver
- Time-stamping of user-defined packets (optional)
- Control of external jitter cleaner PLL
- Analog control loop for external PLL or tunable oscillator (optional)



Lattice Certus Pro NX

- Medium complexity industrial FPGA
- Just a few power supplies required
 - No power sequencing required!
- Low power consumption
- Enhanced design security
- Up to 10Gbit SerDes/Transceiver performance



Certus Pro NX Advantages

- Cost reduction
 - Compared to other 10Gbit capable FPGAs
 - Less components compared to other 10Gbit solutions
 - Less power supplies required
 - No power sequencing required
 - Less PCB layers required
 - Reduced PCB complexity

~USD 40,- BOM
cost reduction

Test Results

- Card is tested now for more than 2 months in our lab
 - Stable solution
- syn1588[®] 10G NIC implemented on the Lattice Certus Pro NX Versa eval board
 - +/-10 ns accuracy even on the evaluation board achieved
- Throughput of approx. 2 Gbit/s achieved
 - Network load test
- PTP measurements done with high-end PTP Grandmaster



Test Results II

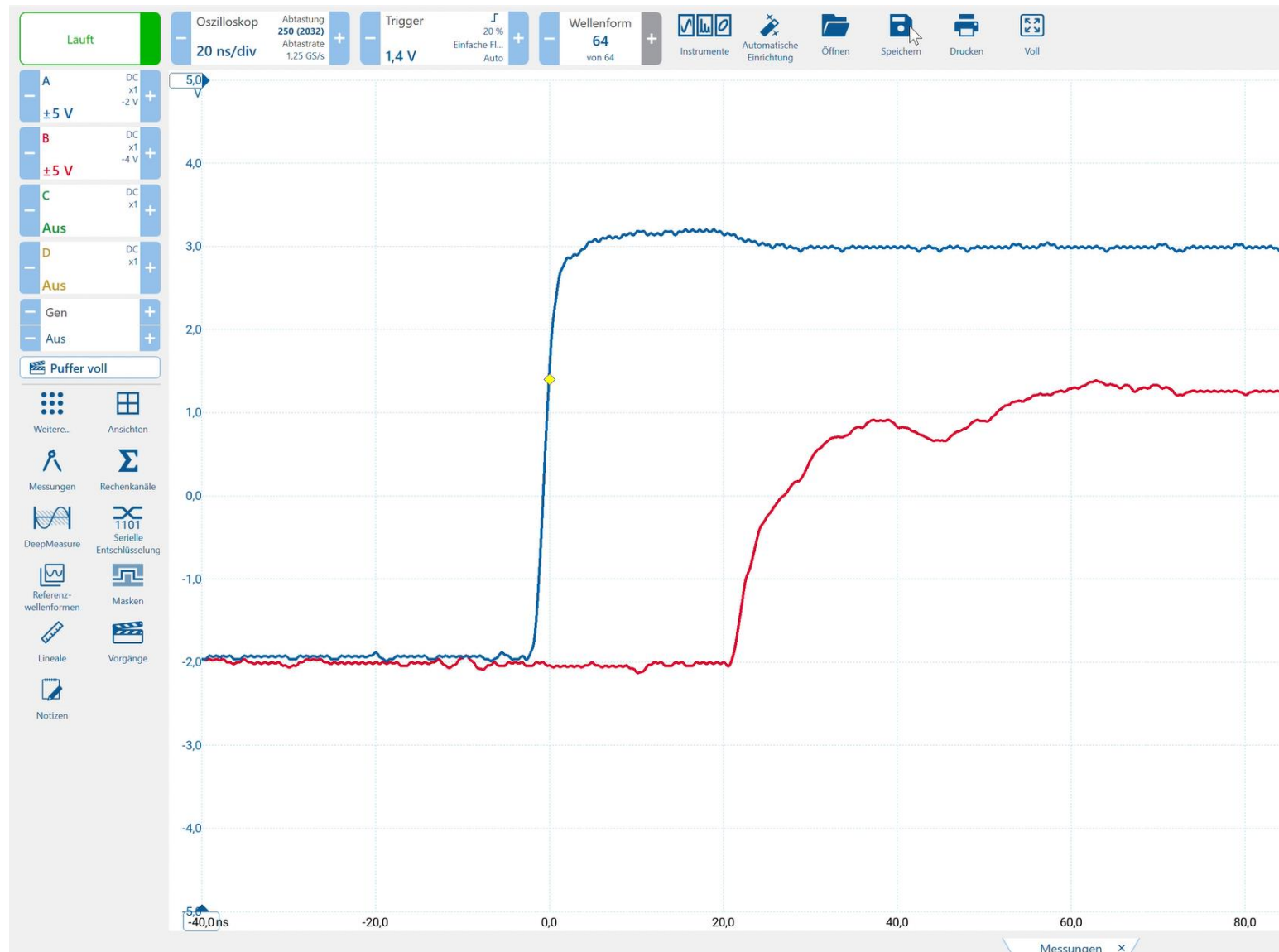

1PPS
Grandmaster

1PPS
syn1588[®] 10G NIC

Constant offset
of ~15 ns due to
evaluation board

Test Setup

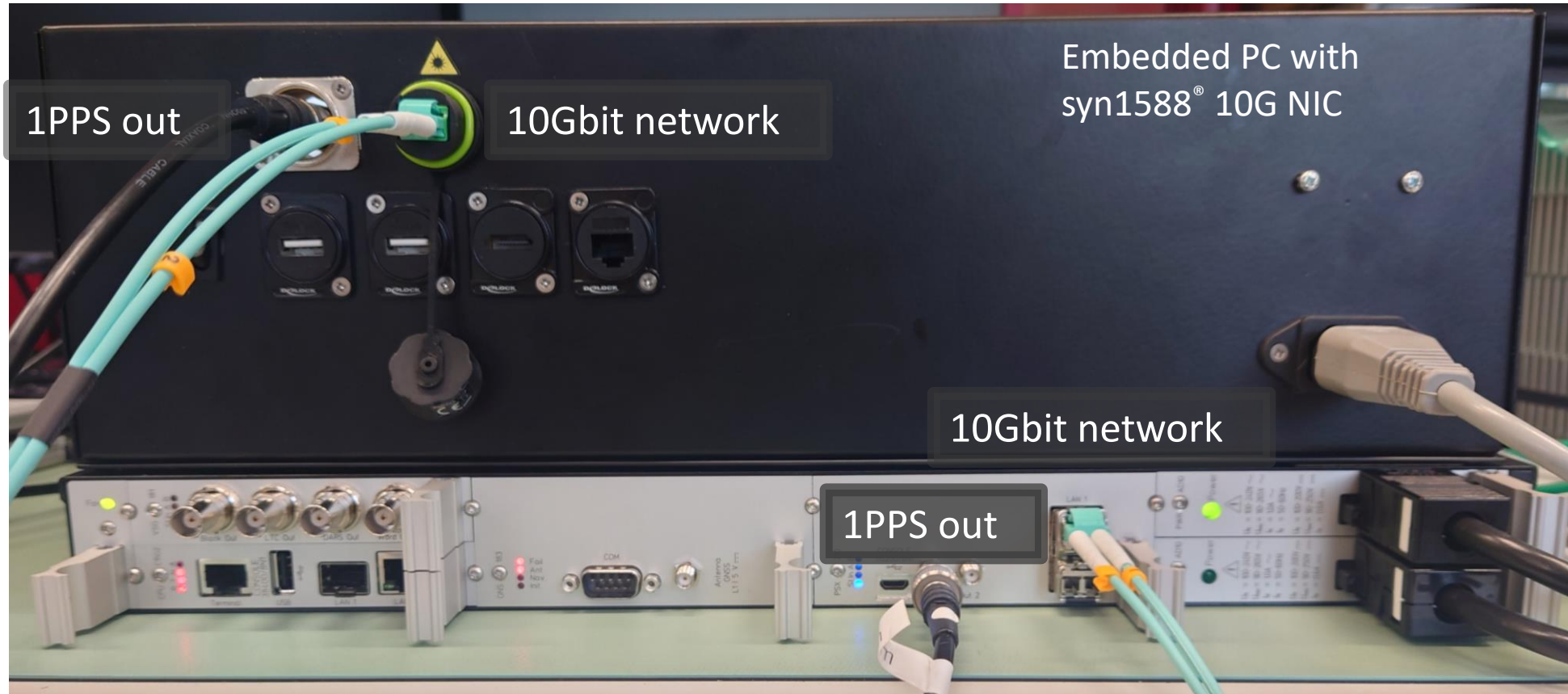

Meinberg M1000 with IMS-PSX210

Test Setup II

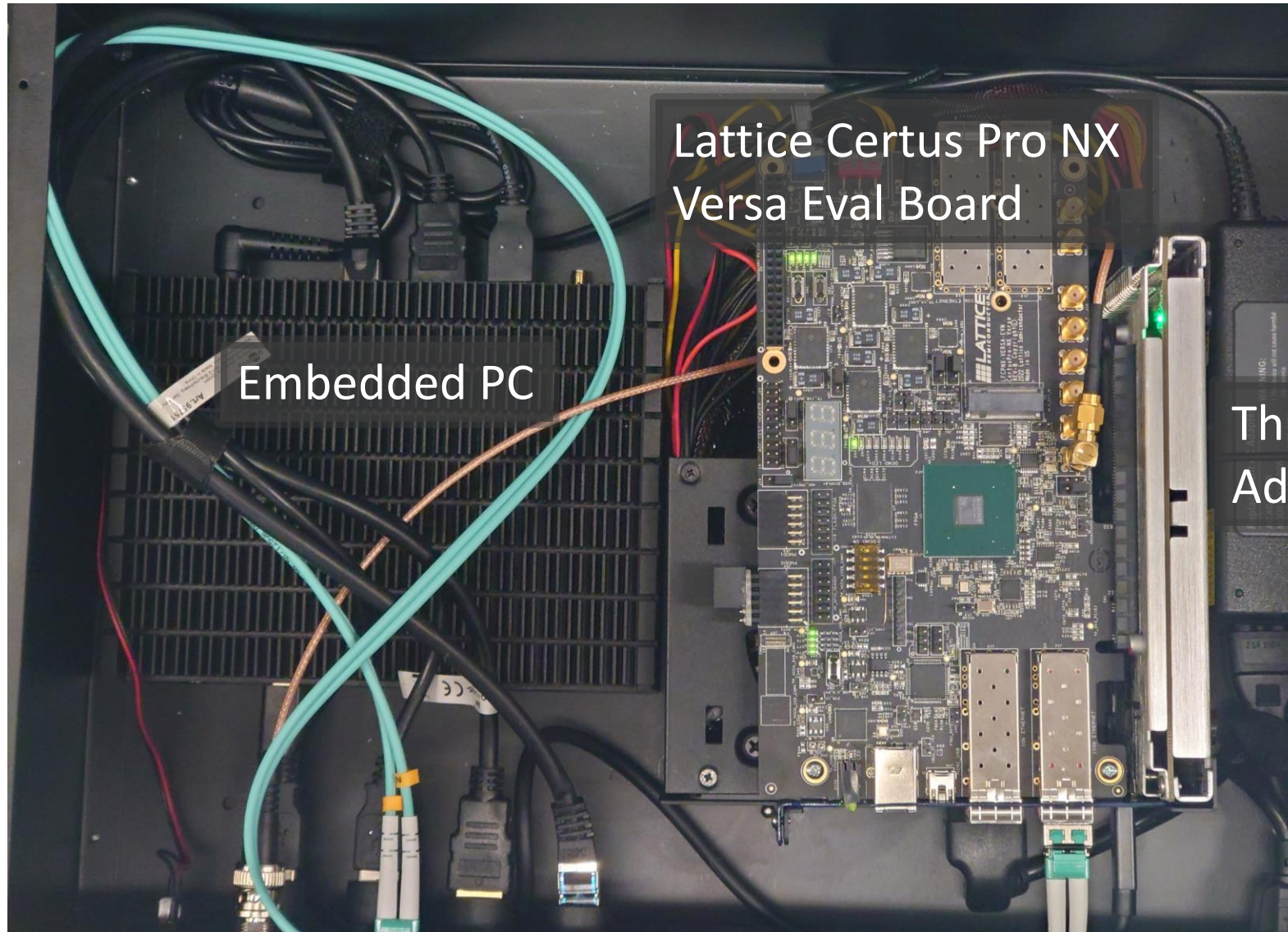

Lattice Certus Pro NX
Versa Eval Board

Embedded PC

Thunderbolt
Adapter

syn1588[®] 10G NIC - Status

- Engineering samples are currently manufactured
- Samples can be ordered in Q1/25
- Volume available in Q2/25
- More information
 - <https://www.oreganosystems.at/products/syn1588/hardware/syn1588r-10g-nic-advance-information>

syn1588[®] 10G NIC - Summary

- Standard 10Gbit Ethernet NIC
- With high-accuracy PTP functions included
- Dedicated PTP board infrastructure
- Full PTP software support
- Verified interoperability

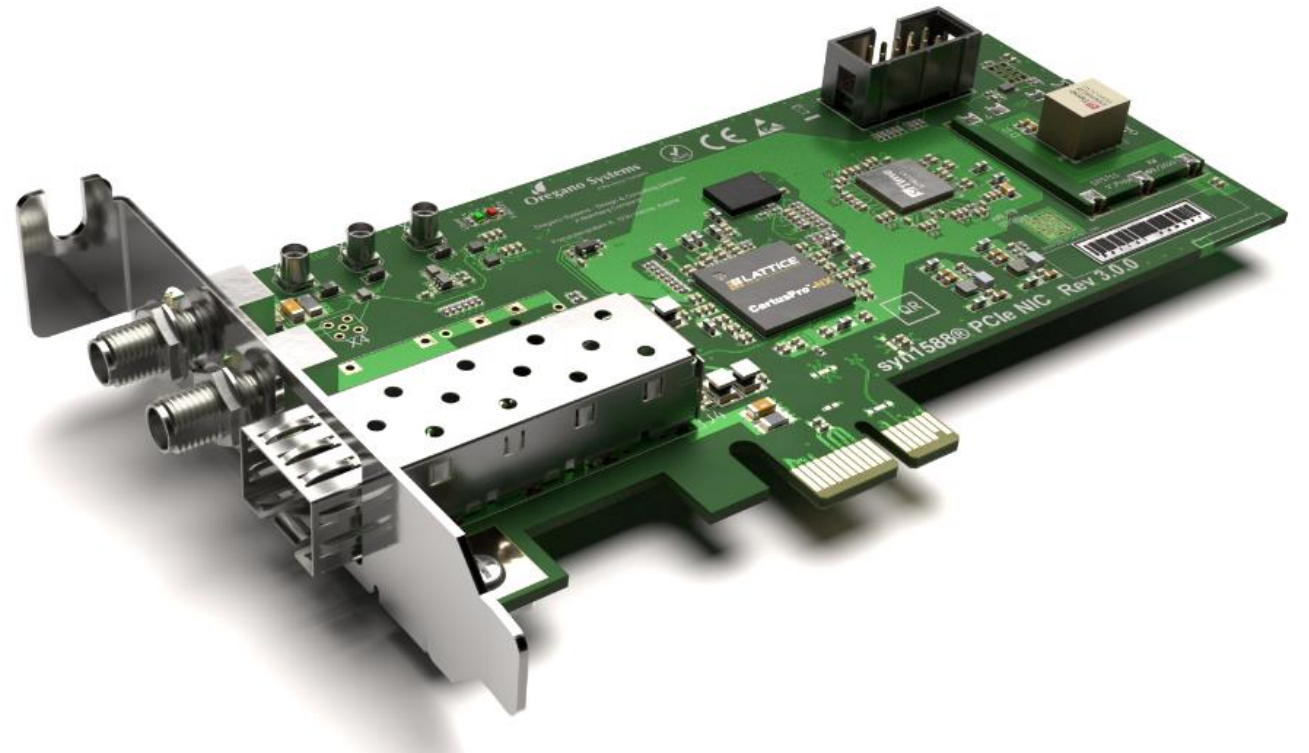

Gerhard R. Cadek
Co-Founder, Senior Hardware Designer

@: cadek@oregano.at

Franzosengraben 8
1030 Vienna
AUSTRIA

<http://www.oregano.at>

